

# Ice Maker

26 lb  
Capacity

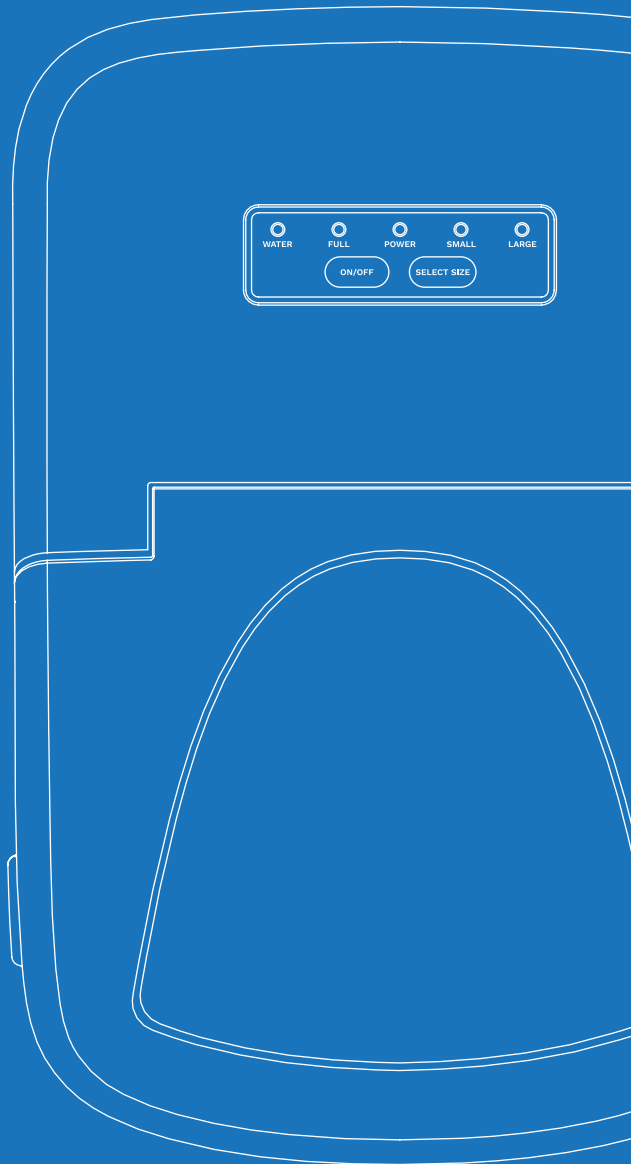

SKU: HME010019N

Thank you for purchasing our appliance. Please be sure to read the entirety of this user manual carefully prior to using this appliance. If you have any questions regarding the use of this product, please call 1-(800)-898-3002.



## Before First Use

To prevent any internal damage, it is very important to keep the unit upright throughout its journey. Please leave it standing upright and outside the box for **24 HOURS** before plugging it in.

In the event this product malfunctions, or you believe it is defective, please contact Customer Service at [homelabs.com/help](https://homelabs.com/help), [1-\(800\)-898-3002](tel:1-800-898-3002) or [help@homelabs.com](mailto:help@homelabs.com) and hold onto the defective product (pending further instruction). A defective product should be clearly marked or stored where it cannot be used by mistake. Failure to keep the product in its original quality from the time of receipt may impede hOmeLabs's ability to correct any legitimate problem and may limit the extent to which hOmeLabs™ may provide recourse.

## Before First Use

We recommend running the cleaning program (See > [Page 10](#)) prior to making ice for the first time.

## Table of Contents

Important Safety Instructions .....	6-7
Getting to know your Ice Maker .....	8-9
Operating Procedures & Maintenance .....	10-11
Troubleshooting .....	12
Warranty .....	13
Warning.....	14
Contact Us .....	14



# Congratulations

on bringing home your new appliance!



Don't forget to register your product at [homelabs.com/reg](https://homelabs.com/reg)  
for updates, coupons, and other relevant information.

Although greatly appreciated, product registration  
is not required to activate any warranty.

# Important Safeguards

---

When using your hOmeLabs Ice Maker (appliance), basic safety precautions should always be followed to reduce the risk of fire, electrical shock, and/or injury to persons. Incorrect operation due to ignoring instructions may cause harm or damage.

## WARNING

## DANGER

These words mean:

- All safety messages will tell you what the potential hazard is, how to reduce the chance of injury, and tell you what can happen if the instructions are not followed.
- Read all instructions before using the appliance.
- Do not operate this or any other appliance with a damaged cord.
- If the cord is damaged, contact hOmeLabs customer service hotline at 1-(800)-898-3002 to avoid a hazard.
- The appliance must be positioned so that the plug is accessible.
- Connect plug to properly polarized outlets only. No other appliance should be plugged into the same outlet. Be sure that the plug is fully inserted into the receptacle.
- Do not run the power cord over carpeting or other heat insulators. Do not cover the cord. Keep the cord away from traffic areas, and do not submerge in water or any other liquid.
- We do not recommend the use of an extension cord, as it may overheat and become a fire risk.
- Unplug the appliance before cleaning or making any repairs or servicing.
- Exercise caution and use reasonable supervision when appliance is used near children.
- Do not use your appliance outdoors. Place the appliance away from direct sunlight and make sure that there is at least 4 inches (101 mm) of space between the back of your appliance and wall. Keep a minimum distance of 4 inches (101 mm) on each side of your appliance free.
- Do not use any other liquid to make ice other than water.
- Do not clean your appliance with flammable fluids. The fumes can create a fire hazard or explosion.
- Do not tip your appliance over.
- If the appliance is stored in a cold environment, wait at least 3 (three) hours for the appliance to warm to room temperature before plugging it in.

**WARNING:** The appliance must be placed on a flat firm surface



**DANGER:** Risk of fire or explosion. Flammable refrigerant used. Do not use mechanical devices to defrost Ice Maker. Do not puncture refrigerant tubing.

**DANGER:** Risk of fire or explosion. Flammable refrigerant used. Appliance should only be repaired by trained service personnel. Do not puncture refrigerant tubing.

**CAUTION:** Risk of fire or explosion. Flammable refrigerant used. Consult repair manual/owner's guide before attempting to install or service this product. All safety precautions must be followed.

**CAUTION:** Risk of fire or explosion. Dispose of appliance in accordance with federal or local regulations. Flammable refrigerant used.

**CAUTION:** Risk of fire or explosion if refrigerant tubing is punctured. Follow handling instructions carefully. Flammable refrigerant used.

## Important Safeguards

---

The ice maker should be installed in accordance with the according to Manufacturer's instructions. Do not install Ice Maker in corridors or hallways of public buildings.

To minimize the risk of possible ignition due to incorrect parts or improper service, all maintenance or servicing must be done by authorized service personnel.

**IMPORTANT:** The wires in this main leads are colored in accordance with the following code:

<b>GREEN OR GREEN WITH A STRIP YELLOW</b>	<b>WHITE</b>	<b>BLACK</b>
Grounding	Neutral	Live

To avoid the appliance falling or tipping over, always place on a flat, sturdy surface. Damage may occur if the appliance falls.

**SAVE THESE INSTRUCTIONS**

For Household Use Only

# Getting to know your Ice Maker

## PARTS OVERVIEW

1. Ice Scoop
2. Full Sensor – Detects ice levels
3. Ice Basket
4. Water Tank – Located under Ice Basket
5. Top Cover with Transparent Window
6. Air Outlet
7. Water Drain Cap - Located at the front bottom side of the appliance
8. MAXIMUM WATER LEVEL - Remove the Ice Basket, to see the water level mark

**IMPORTANT!** Do not block Air Outlet.

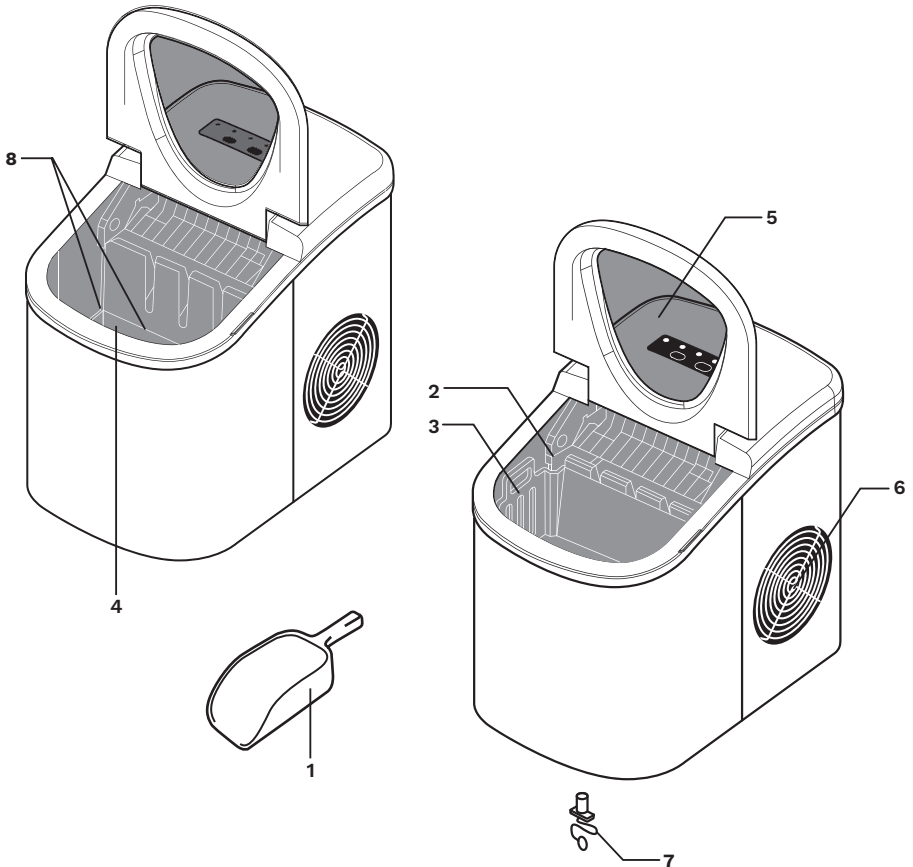



# Getting to know your Ice Maker

## CONTROL PANEL FUNCTIONALITY

Use the Control Panel buttons to select the size of your ice and to power on the appliance. There are 5 indicator lights (Water, Full, Power, Small, Large).

- **ON/OFF BUTTON** – The POWER LED will illuminate when you turn on the appliance with this button.
- **SELECT SIZE BUTTON** – Click on this button to cycle through options and select the desired ice size (LEDs: S-SMALL or L-LARGE).
- **WATER LED** – Illuminates when there is a water shortage in the tank.
- **FULL LED** – Indicates when your Ice Basket is full.

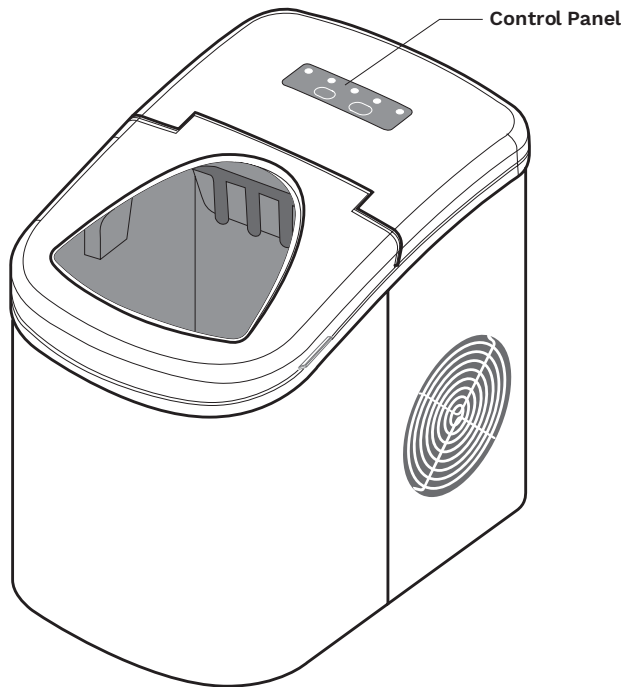

## CONTROL PANEL DETAILS

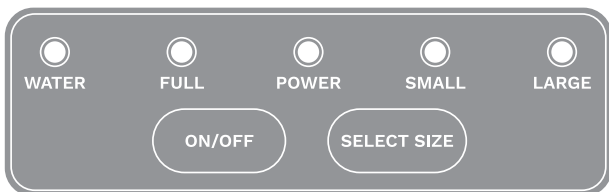

# Operating Procedures & Maintenance

---

## BEFORE FIRST USE

1. Remove all packaging materials from interior of the Ice Maker. Confirm Ice Basket and Ice Scoop are inside. If any parts are missing, please contact Customer Service at [homelabs.com/help](http://homelabs.com/help), 1-(800)-898-3002 or [help@homelabs.com](mailto:help@homelabs.com).
2. Remove the tape holding the Ice Shovel, Ice Basket, and Ice Scoop to the appliance.
3. Clean the Tank and Ice Basket with warm soap and water. Allow parts to dry completely.
4. Place the Ice Maker on a flat, even surface without direct sunlight and/or other sources of heat (i.e., stove, furnace, radiator). For proper ventilation, ensure there is at least a 4 inch (101 mm) gap between the appliance exterior and any surfaces nearby.
5. Wait one hour for the refrigeration fluid to settle, then plug in the appliance.
6. Leave appliance upright for 24 hours before initial power up.

**NOTE:** The appliance plug must be accessible.

## IMPORTANT POWER NOTICES

- This appliance should be properly grounded for your safety. The power cord of this appliance is equipped with a three-prong plug which couples with standard three prong wall outlets to minimize the possibility of electric shock.
- Plug your appliance into a secure, properly installed, grounded wall outlet. Do not under any circumstances, cut or remove the third (ground) prong from the power cord. Any questions concerning power and/or grounding should be directed toward a certified electrician.
- This appliance requires a standard 110–120 V, 60 Hz electrical outlet with three-prong ground.

## USING YOUR ICE MAKER

Ensure your Ice Maker is clean before making any ice.

1. Open the cover, remove the Ice Basket and pour water into the Tank. Keep water level below the water level mark (See > [Page 9](#)) for location.

**NOTE:** Use filtered water to limit the risk of contamination and reduce scale buildup.

2. Press the “POWER” button on the control panel to begin the ice making cycle.

**NOTE:** Leave the Top Cover closed at all times except when adding water or scooping out ice.

3. Select the ice cube size by pressing the “SELECT SIZE” button. If the room temperature is lower than 60°F (15°C), it is recommended to select small in order to avoid ice sticking together.
4. The ice making cycle lasts approx. 6 to 13 minutes, depending on selection of ice cube size and the room temperature. The recommended room temperature is 50°F to 105°F (10°C to 40°C).

# Operating Procedures & Maintenance

---

**NOTE:**

- Always use the scoop to remove ice from the machine, do not use your hands or fingers as it may contaminate the ice machine.
- Do not return ice into the ice maker, it can introduce dirt and germs into the machine.

5. If water pump can't inject water, the appliance will stop automatically, and the "WATER" shortage indicator will turn on. Press "POWER" button, fill water up to the max water level mark and press "POWER" button again to turn on the appliance. Allow the refrigerant liquid inside the compressor to settle for at least 3 minutes before restarting.
6. The appliance stops when the Ice Basket is full and the ice "FULL" indicator is on.

**WARNING:** Direct sunlight or sunlight reflection may cause infrared sensor malfunction. If the appliance doesn't stop even when ice cubes obstruct the sensor, move the appliance away from sunlight.

7. Change water in the Water Tank every 24 hours to limit mold and bacteria growth. If the appliance won't be used for an extended period to be used, drain all the water from the appliance and ughly to avoid damage to the appliance.

## CLEANING AND MAINTAINING YOUR ICE

Before using your appliance, it is strongly recommended to clean it thoroughly.

1. Remove the Ice Basket from the appliance.
2. Clean the interior of the appliance with diluted detergent, warm water and a soft cloth.

**NOTE:** Do not immerse the ice maker in water or any other liquid.

3. Use the water to rinse the inside parts, and drain out the water by unplugging the drain cap on front bottom of the appliance.
4. The outside of the appliance should be cleaned regularly with a mild detergent solution and warm water.
5. Dry the interior and exterior of the appliance with a clean, soft cloth.
6. When the appliance is not in use for an extended period of time, drain water completely and dry the interior of the appliance.
7. Clean the scoop regularly using warm soapy water and allowing it to dry before using it again.
8. The Air Outlet on the ice machine should be checked regularly for dirt or dust build-up. With the power off, use a soft dry brush to gently remove any build-up from the vents.
9. This ice maker does not have a cleaning function. If using a standard ice maker or freezer cleaning solution, follow the instructions provided by the cleaning solution's manufacturer. You will use a normal ice making cycle. Use a normal ice making cycle and follow the cleaning solution manufacturer's instructions.

## Troubleshooting

PROBLEM	POSSIBLE CAUSE	SOLUTION
WATER shortage indicator is on.	Lack of Water.	Stop the appliance, by pressing the “ON/OFF” button. Fill Tank with water, and press “ON/OFF” button again to restart the appliance.
FULL indicator is on.	Basket is full of ice.	Remove ice from ice basket. Continuously hold “SELECT SIZE” button for 5 seconds, the appliance can make 10 even cycles of ice even when “FULL” indicator is on.
Ice cubes are sticking together.	The ice making cycle is too long.  Water temperature in inner tank is too low.	Stop the appliance by pressing the “ON/OFF” button, and restart it when the ice blocks melt. Select the small size ice cube selection.  Replace the water. Temperature of water recommended at 40°F–90°F (4°C–32°C).
Ice making cycle is normal but no ice is being formed.	Room temperature or water temperature in inner tank is too high.  Refrigerant in cooling system is leaking.  Pipe in the cooling system is blocked.	The room temperature should be: 50°F–105°F (10°C–40°C), The water temperature should be: 40°F–90°F (4°C–32°C)  Contact hOmeLabs Customer Service at 1-(800)-898-3002  Contact hOmeLabs Customer Service at 1-(800)-898-3002
Mold	Various causes	If you notice mold or other residue building up on the ice maker, it should be powered-off and cleaned thoroughly. Use room temperature water and mild detergent with a soft cloth to clean all inside surfaces, rinse with water and then run 3 cycles of ice making with new water each time, discarding the ice. Ideally also use professional ice machine descaler and sanitizer solutions, following manufacturer’s instructions for use.  Provided the water, scoop, ice machine and immediate environment are kept clean and hygienic, mold should be avoided.
Water leakage	Drain Cap is not in place.	Ensure the Water Drain Cap (front bottom of unit) is in place.

## Warranty

---

hOmeLabs offers a limited one-year warranty (“warranty period”) on all of our products purchased new and unused from hOmeLabs, LLC or an authorized reseller, with an original proof of purchase and where a defect has arisen, wholly or substantially, as a result of faulty manufacturing, parts, or workmanship during the one-year warranty period. The warranty does not apply where damage is caused by other factors, including, but without limitation to: (a) normal wear and tear; (b) abuse, mishandling, accident, or failure to follow operating instructions; (c) exposure to liquid or infiltration of foreign particles; (d) servicing or modifications of the product other than by hOmeLabs™; (e) commercial or non-household use.

The hOmeLabs warranty covers all costs related to restoring the proven defective product through repair or replacement of any defective part and necessary labor so that it conforms to its original specifications. A replacement product may be provided instead of repairing a defective product. hOmeLabs's exclusive obligation under this warranty is limited to such repair or replacement.

A receipt indicating the purchase date is required for any claim, so please keep all receipts in a safe place. We recommend that you register your product on our website: [homelabs.com/reg](http://homelabs.com/reg). Although greatly appreciated, the product registration is not required to activate any warranty and product registration does not eliminate the need for the original proof of purchase. The warranty becomes void if attempts at repair are made by non-authorized third parties and/or if spare parts, other than those provided by hOmeLabs, are used. You may also arrange for service after the warranty expires at an additional cost.

These are our general terms for warranty service, but we always urge our customers to reach out to us with any issue, regardless of warranty terms. If you have an issue with a hOmeLabs product, please contact us at 1-(800)-898-3002, and we will do our best to resolve it for you.

This warranty gives you specific legal rights, and you may have other legal rights which vary from state to state, province to province, or country to country. The customer may assert any such rights at their sole discretion.

## Manufacturing Information

---

This manual covers all items with these model numbers:

HME010019N

SKU: HME010019N

Rated Voltage/Frequency: 115 V~ 60 Hz

Weight: 16.31 lb

Dimensions: H 12.9 × W 9.5 × L 14 inches

Recommended Room Temperature: 50°F to 105°F (10°C to 40°C).

**WARNING: Keep all plastic bags away from children.**

**WARNING:** This product can expose you to chemicals including Lead and Phthalates, which are known to the State of California to cause cancer and birth defects or other reproductive harm. For more information go to [www.P65Warnings.ca.gov](http://www.P65Warnings.ca.gov).

## Contact Us

---

 CHAT WITH US

[homelabs.com/help](http://homelabs.com/help)

 CALL US

1-(800)-898-3002

 EMAIL US

[help@homelabs.com](mailto:help@homelabs.com)





## For Household Use Only

**Distributed by h0meLabs, LLC**  
37 East 18 Street, 7th Floor  
New York, USA 10003

1-(800)-898-3002  
[help@homelabs.com](mailto:help@homelabs.com)  
[homelabs.com/help](https://homelabs.com/help)

All rights reserved, h0meLabs.  
Made in China.